

**Lehigh Acres Fire Control
and Rescue District**



**Commission Meeting
April, 2007**

MINUTES

LEHIGH ACRES FIRE CONTROL AND RESCUE DISTRICT

COMMISSION MEETING

March 21, 2007

The March 21, 2007 meeting of the Lehigh Acres Fire Control and Rescue District Board of Commissioners was opened at 7:40pm by President Hemingway. Present were: Commissioners Berndt, Guzman, Hemingway, Barrett and Boyd; Chief Adams, Assistant Chief Haugh, Battalion Chief Christensen and Administrative Assistant Platas. Attorney Pringle was also in attendance. The meeting was held in the bay of 1000 Joel Blvd., due to a large attendance.

After the Pledge of Allegiance, Commissioner Hemingway asked Chief Don Adams to give the invocation.

Commissioner Hemingway asked if there were any additions, corrections, or deletions to the Agenda. Chief Adams added Assistant Chief Job Description, PIO position vehicle, Announce and introduce the PIO and AC and Attorney Pringle to give a FGUA presentation. Commissioner Hemingway added Letter to the "higher ups" on the installation of the traffic light at Bell and Milwaukee Blvds. *Commissioner Boyd motioned to accept the Agenda as amended with a second from Commissioner Guzman. Motion passed.*

Steve Brettholtz from Myers Brettholtz and Company, independent auditors spoke and stated highlights of the 2005/06 audit report.

Commissioner Hemingway asked if there were any corrections, additions or deletions to the minutes. *Commissioner Guzman motioned to accept the minutes of the February 3, 2007 Commission Workshop, February 3, 2007 Special Meeting and February 21, 2007 regular Commission Meeting. Commissioner Boyd seconded. Motion passed.*

PUBLIC COMMENT (on Agenda Items):

None.

TREASURER'S REPORT:

Commissioner Guzman read points of interest on the Treasurers Report for the month of February 2007. *Commissioner Boyd motioned to accept the minutes subject to audit with a second from Commissioner Barrett. Motion passed.*

CHIEF ADAMS:

Chief Adams spoke on the following items:

- Tony DeSanto, DVP of Local 1826, District 6 resigned his position of DVP. Walt Stevens from the downtown local is stepping in for now.
- The County Commissioners issued a burn ban for Lee County.
- Met w/ Country Club Owners Association regarding discussion of the live burn.

ASSISTANT CHIEF OPERATIONS JOB DESCRIPTION – Chief Adams would like to remove that part of the job description that required the AC OPS to obtain a paramedic license within one year of employment. He stated the AC will be busy getting adjusted with the job. *Commissioner Guzman motioned that we go w/recommendation of Chief and remove this stipulation in the job description with second from Commissioners Boyd/Barrett. Motion passed.*

PIO POSITION – ISSUING OF A VEHICLE – Chief Adams would like to afford the PIO the latitude of taking home a vehicle. He stated it was standard across Lee County. Vehicle will be used for business only. It won't be emergency response. *Commissioner Guzman motioned that we accept recommendation of Chief and allow the PIO to take a vehicle home with second from Commissioner Barrett. Motion passed.*

PRESENT CHOSEN CANDIDATE FOR AC OF OPERATIONS – Chief Adams stated Mr. Solon Duncan was chosen for the position of Assistant Chief of Operations.

PRESENT CHOSEN CANDIDATE FOR PIO – Chief Adams stated Mr. Patrick Comer was chosen for the position of Public Information Officer.

No starting date as of yet.

ASSISTANT CHIEF HAUGH:

- Calls are up.
- We just ordered an engine and 2 ambulances. Delivery estimated October 2007.
- Credentialed 2 paramedics.

COMMISSIONERS REPORTS:

None.

UNFINISHED BUSINESS:

INTERNATIONAL UNION OF PAINTERS AND ALLIED TRADES – Mr. Joe Dykers stated he is here to ask the Commissioners to authorize the unit for bargaining. He stated he has 5 of 6 authorized signed cards. Attorney Pringle stated at this point, the Board either needs to recognize or not recognize the union. That's the first thing the Board has to do. Commissioner Guzman stated this union is going against the Chief. He stated the Chief and Attorney are working on a handbook for 40 hour people to follow for benefits, etc. He is totally against the organization of this union. Chief Adams stated he wanted all 40 hour employees to be created fairly and equally. Commissioner Berndt stated when we discussed this in the past, we empowered the Chief to run the District as he sees fit and do things that he feels would be most successful for the District. Parity and equity was the Chief's goal. Commissioner Berndt says this would be a compete 180.

Mr. Dykers stated any 2 people or more have the right to organize in this state. It would be beneficial to the department to recognize when there is such a great support for this union. Commissioner Hemingway stated it takes a lot of time for negotiations. Commissioner Boyd stated they are not represented. *Commissioner Guzman motioned that we do not recognized this bargaining unit for the 3 secretarial positions, tradesperson, bookkeeper and billing specialist with second from Commissioner Berndt. Motion passed 4-1 with the dissenting vote from Commissioner Boyd.*

Mr. Dykers stated he is advising the Commission that he will be filing part 3 for an election with PERC. He will do the necessary paperwork.

NEW BUSINESS:

STATIONS 4 AND 5 - Rob Fowler spoke on Stations 4 and 5. Rob Fowler's role as construction manager was to be proactive on Stations 4 and 5. He was also asked to come up with temporary administration building. He gave a handout to the Commissioners regarding temporary admin buildings.

COMMISSIONERS MANUAL – Commissioner Berndt began by stating under Composition of the Board – the last paragraph. We discussed at that time to insert the word “may” fill the vacancy according to state statutes. Attorney Pringle stated Chapter 191 of the FS addresses filling a vacancy of a Commission seat. Legislation decided to fill a vacancy by Commissioners.

FS 191.005 - If a vacancy occurs on the board due to the resignation, death, or removal of a board member or the failure of anyone to qualify for a board seat, the remaining members may appoint a qualified person to fill the seat until the next general election, at which time an election shall be held to fill the vacancy for the remaining term, if any. The board shall remove any member who has three consecutive, unexcused absences from regularly scheduled meetings. The board shall adopt policies by resolution defining excused and unexcused absences.

Attorney Pringle stated you could say.....the Board may fill a vacancy pursuant to FS law. Subsection 5 of the Florida Statutes would then govern. Attorney Pringle suggests to have a motion to include this language.

Commissioner Berndt motioned that we change the language to....."should a Commissioner fail to complete his or her term for any reason, the remaining members of the governing Board "may fill the vacancy in accordance with Florida State Statutes". Commissioner Guzman seconded the motion. We will follow the FS 191.005 Commissioner Hemingway commented. Motion passed.

Page 4, Procedural Rules for Board Meetings – under #1, Governing Rules...

Commissioner Berndt motioned that we change the word "shall" in that paragraph to "may" follow Roberts Rules with a second from Commissioner Guzman. After some discussion regarding which version of Roberts Rules to follow, Commissioner Berndt amended his motion to add, "may be governed by Roberts Rules of Order revised" More discussion followed. Commissioner Berndt requested to delete his motion with no objections.

Commissioner Berndt motioned that we change the remaining language to: "Roberts Rules of Order Revised may be used as a guide" with a second from Commissioner Guzman. Attorney Pringle stated the most recent edition of the Roberts Rules should be used. After additional discussion, Commissioner Berndt amended his motion to state the most recent edition of Roberts Rules may be used with a second from Commissioner Guzman. Motion passed.

Page 7 under Order of Business, Chief Adams would like to add "Consent Agenda" to include the minutes. Items can be pulled off of the Consent Agenda at any time prior to adoption.

Discussion was also to place Attorney Pringle at the bottom of department reports. Remove "by assignment" after Commission reports.

Commissioner Berndt motioned that we add Consent Agenda to the monthly agenda with a second from Commissioner Guzman. Motion passed.

Commissioner Berndt motioned we add Attorney's Report under Department reports with a second from Commissioners Guzman and Barrett. Motion passed.

Commissioner Guzman motioned on Item 10, by assignment be stricken with a second from Commissioner Barrett. Motion passed.

Page 8, #6 under Parliamentarian, change all words of *shall* to may in this paragraph. Commissioner Berndt made a motion to strike through the word *shall* in this paragraph and replace with the word may. Second from Commissioner Barrett. Motion passed.

Page 12, #10 under Adjournment, Commissioner Guzman motioned that we change the time from 11pm to 10pm with a second from Commissioner Barrett. Changed in both locations. Put to a vote, the motion passed.

Chief Adams stated about having people who want to talk complete a card if they wish to speak as stated on page 11, Section D, subsection c. This will be implemented at the April meeting.

ORGANIZATIONAL CHART – Chief Adams spoke on the organizational chart for the department. He made some changes for the department on reporting issues. (copy attached). *Commissioner Berndt motioned to accept the organizational chart as revised and presented by Chief Adams with a second from Commissioner Guzman. Motion passed.*

WRITE OFF ALARM – Chief Adams stated a resident is requesting the Commission to write off an alarm activation charge due to hardship. *Commissioner Guzman motioned to write off the alarm activation charge for Statement #9727 with a second from Commissioner Berndt. Motion passed.*

ACCEPT AUDIT REPORT - *Commissioner Guzman motioned to accept the 2005/06 audit with second from Commissioner Boyd. Motion passed.*

ATTORNEY PRINGLE spoke on the water line. He created an RFQ, a Request for qualifications/proposals. It has been reviewed by Construction Manager. FGUA has it as of today. East County Water approved for us to place the water line in their boundaries. FGUA wants us to pay for 6" line capacity even though our engineers say we only need a 4" capacity. FGUA has to approve this document (RFQ). FGUA will not commit at this time to what size water line they will put in. If FGUA says its fine and authority is given to post now, it may not delay Station 4.

Rob Fowler stated it is imperative that action be taken on this right away, authorization to put out the RFQ.

Commissioner Guzman motioned that Attorney Pringle proceed with the Request for Qualification/Proposal with a second from Commissioner Boyd. Pass.

Attorney Pringle also spoke on the RFQ for architects. It was limited to St. 4 and 5 only. There are a multitude of other items that require architectural services. *Commissioner Guzman motioned that we move forward with an RFQ for architectural services for work other than St. 4 and 5 with a second from Commissioner Berndt. Motion passed.*

STOP LIGHT – Commissioner Hemingway stated the reason why he is bringing this up is all the construction going on in the area of Bell Blvd and Milwaukee Blvds. He is requesting the Chief send a forceful letter to the County Highway Dept and also the Lee County Attorney, County Commissioners, etc. We want a stop light immediately. Chief will write this letter.

PUBLIC COMMENTS:

Sonny Haas, resident of Lehigh Acres stated he says to the staff and Commissioners – please allow your state certified construction manger and attorney do the job they were hired to do.

Whitey Doidge, Lehigh Acres resident stated Commissioners need to do something with the audio in the bay. He also commented about the two union firemen rejecting the girls going into a union. Mr. Doidge stated he can hardly hear the Chief. What is the salary of the PIO? Chief answered \$65,000 a year. Mr. Doidge questioned vacation time of the PIO. Chief answered 2 weeks a year. Mr. Doidge questioned where the money is coming from. Chief answered General Fund. Mr. Doidge stated the PIO shouldn't have a vehicle with lights and siren. Has nothing against the PIO. \$65,000 is a nice salary.

Gorden Despot, Lehigh resident addressed Comm Hemingway. Need to get control of the public comments. Commissioners and Chief are not allowed to comment back and forth with the public. If someone wants to ask a question, there is proper protocol for that.

Matt Hepner, Lehigh resident thanked Commissioners, Chief and staff. He was an explorer for 8 years. He also spoke on comments made to Chief Adams last meeting. They were unwarranted.

Mrs. Piper, Lehigh resident stated this may be her last meeting. She may be moving. Thank all for what they have done.

COMMISSIONER COMMENTS:

Commissioner Berndt stated what a terrific crowd. We need a different venue. Sound system or appropriate taping equipment is needed.

Commissioner Barrett thanked the public. A lot discussed and a lot accomplished.

Commissioner Guzman welcomed new employees. Remind Commissioner we are elected officials. Every comment we make, we represent this Board.

Commissioner Boyd stated he is happy to see crowd and congratulated new employees.

Commissioner Hemingway welcomed new employees. Pleased for the crowd. Congratulations to Fowler Company.

ADMINISTRATIVE COMMENTS:

Chief Adams thanked Commissioners and staff.

Adjourn 9:53pm.

Lehigh Acres Fire Control and Rescue District
Receipts and Disbursements
For the sixth month ending March 31, 2007

	Period To Date		Annual Budget	Year To Date		Budget Variance
	Actual	%		Actual	%	
Beginning Cash	-		\$ 13,610,099.00	\$ 13,477,163.53	99.02%	\$ (132,935.47)
Ad Valorem Taxes	996,278.43	5.10%	19,534,564.00	14,692,645.29	75.21%	(4,841,918.71)
Grants	-	0.00%	-	-	0.00%	-
Donations	-		200.00	75.00	37.50%	(125.00)
William Ziegler Memorial	-		-	300.00		300.00
Inspection Fees	2,605.00	5.21%	50,000.00	23,525.60	47.05%	(26,474.40)
Ambulance Billing	87,851.61	9.50%	925,000.00	470,067.48	50.82%	(454,932.52)
Suppression Fees	61.00	0.00%	-	121.51	0.00%	121.51
Interest	83,759.71	55.84%	150,000.00	415,769.05	277.18%	265,769.05
Impact Fees	-	0.00%	2,000,000.00	936,372.98	46.82%	(1,063,627.02)
Proceeds from Insurance	-	0.00%	-	5,000.00	0.00%	5,000.00
Miscellaneous Income	5,659.94	37.73%	15,000.00	12,241.64	81.61%	(2,758.36)
Prevention Fees & Sales	390.00	7.80%	5,000.00	1,282.00	25.64%	(3,718.00)
Construction Loan Proceeds	-		-	-		-
Total Receipts	\$ 1,176,605.69	3.24%	36,289,863.00	30,034,564.08	82.76%	(6,255,298.92)
Disbursements						
1100 Salaries	898,791.59	10.62%	8,466,230.00	3,654,364.67	43.16%	4,811,865.33
1200 Employee Benefits	419,932.58	8.97%	4,683,208.00	2,215,418.04	47.31%	2,467,789.96
3310 Professional Services	17,892.40	3.98%	449,210.00	146,485.09	32.61%	302,724.91
3340 Contract Services	-	0.00%	40,000.00	150.00	0.38%	39,850.00
3400 Travel Commission	-	0.00%	1,000.00	-	0.00%	1,000.00
3410 Communications	5,056.46	7.69%	65,740.00	38,679.62	58.84%	27,060.38
3430 Utilities	4,324.32	4.35%	99,500.00	27,619.17	27.76%	71,880.83
3440 Rentals	375.00	0.14%	269,000.00	16,900.00	6.28%	252,100.00
3450 Insurance/General	7,342.00	7.34%	100,000.00	79,718.43	79.72%	20,281.57
3460 Maintenance	16,000.09	4.88%	328,200.00	123,811.42	37.72%	204,388.58
3480 Promotional	(120.00)	-0.48%	25,000.00	1,293.57	5.17%	23,706.43
3490 Other Current Charges	3,585.31	0.51%	702,700.00	81,848.79	11.65%	620,851.21
3510 Office	1,574.61	4.50%	35,000.00	17,218.26	49.20%	17,781.74
3520 Operating Supplies	38,132.57	6.01%	634,150.00	240,268.34	37.89%	393,881.66
6600 Capital	666,013.13	4.13%	16,125,233.00	2,748,033.68	17.04%	13,377,199.32
7700 Debt Service	-	0.00%	3,000.00	-	0.00%	3,000.00
9900 Reserves	-	0.00%	3,262,692.00	-	0.00%	3,262,692.00
9905 Disaster Reserves	-		1,000,000.00	-		-
TOTAL DISBURSEMENTS	\$ 2,078,900.06	5.73%	\$ 36,289,863.00	\$ 9,391,809.08	25.88%	\$ 25,898,053.92
YTD NET				\$ 20,642,755.00		

These reports are provided on a cash basis and are intended for internal use only.

**LEHIGH ACRES FIRE CONTROL RESCUE DISTRICT
BREAKDOWN OF ACCOUNTS
FOR THE SIXTH
MONTH ENDING MARCH 31, 2007**

	PERIOD TO DATE			YEAR TO DATE		
	Actual	%	Annual Budget	Actual	%	Budget Variance
1100 SALARIES						
1105 Commission Salary	2,500.00	8.33%	30,000.00	14,000.00	46.67%	16,000.00
1110 Administrative Salaries	89,257.72	8.83%	1,010,860.00	418,450.56	41.40%	592,409.44
1120 Regular Salaries	757,900.77	11.17%	6,782,370.00	2,925,423.78	43.13%	3,856,946.22
1130 Holiday Pay	17,833.63	8.92%	200,000.00	149,606.50	74.80%	50,393.50
1140 Overtime	31,299.47	15.65%	200,000.00	123,926.24	61.96%	76,073.76
1150 Sick Time	-	0.00%	103,000.00	-	0.00%	103,000.00
1160 Annual Sick Time Pay	-	0.00%	140,000.00	22,967.59	16.40%	117,042.41
Total Salaries	898,791.59	0.11	8,466,230.00	3,654,364.67	43.16%	4,811,865.33
1200 EMPLOYEE BENEFITS						
1210 Payroll Tax Expense	68,757.65	10.75%	639,787.00	275,288.87	43.03%	364,498.13
1220 Retirement	179,226.41	10.77%	1,663,800.00	723,881.22	43.51%	939,918.78
1230 Group Insurance	133,107.04	7.29%	1,827,121.00	713,441.50	39.05%	1,113,679.50
1240 Worker's Compensation	38,841.48	7.06%	550,000.00	502,806.45	91.42%	47,193.55
1250 Unemployment Compensation	-	0.00%	2,500.00	-	0.00%	2,500.00
Total Employee Benefits	419,932.58	8.97%	4,683,208.00	2,215,418.04	47.31%	2,467,789.96
3310 PROFESSIONAL SERVICES						
3311 Property Appraiser	-	0.00%	112,710.00	51,825.90	45.98%	60,884.10
3312 Legal Fees	12,396.40	6.20%	200,000.00	46,545.32	23.27%	153,454.68
3313 Medical Director	5,000.00	8.33%	60,000.00	30,000.00	50.00%	30,000.00
3314 Physicals	496.00	0.83%	60,000.00	8,259.00	13.77%	51,741.00
3315 Land Taxes	-	0.00%	1,500.00	1,211.05	80.74%	288.95
3319 Miscellaneous Bank Charges	-	-	-	126.42	-	-
3320 Audit	-	0.00%	15,000.00	8,517.40	56.78%	6,482.60
Total Professional Services	17,892.40	3.98%	449,210.00	146,485.09	32.61%	302,851.33
3340 CONTRACT SERVICES						
3342 Outside Maintenance	-	0.00%	10,000.00	150.00	1.50%	9,850.00
3344 5 Year Plan	-	0.00%	30,000.00	-	0.00%	30,000.00
Total Contract Services	-	0.00%	40,000.00	150.00	1.50%	39,850.00
3400 TRAVEL/COMMISSION	-	0.00%	1,000.00	-	0.00%	1,000.00
3410 COMMUNICATIONS	5,056.46	7.69%	65,740.00	38,679.62	58.84%	27,060.38
3430 UTILITIES						
3431 Electric	2,969.83	4.22%	70,200.00	19,060.01	27.15%	51,139.99
3432 Utilities	1,364.49	4.66%	29,300.00	8,559.16	29.21%	20,740.84
Total Utilities	4,324.32	4.35%	99,500.00	27,619.17	27.76%	71,880.83
3440 RENTALS	375.00	0.14%	269,000.00	16,900.00	6.28%	252,100.00
3450 INSURANCE (GENERAL)	7,342.00	7.34%	100,000.00	79,718.43	79.72%	20,281.57
3460 MAINTENANCE						
3461 Building Maintenance	2,919.37	4.49%	65,000.00	11,199.07	17.23%	53,800.93
3462 Equipment Maintenance	779.54	2.36%	33,000.00	5,867.88	17.78%	27,132.12
3463 Vehicle Maintenance	6,484.68	5.64%	115,000.00	44,105.74	38.35%	70,894.26
3464 Maintenance Contracts	5,816.50	5.05%	115,200.00	62,638.73	54.37%	52,561.27
Total Maintenance	16,000.09	4.88%	328,200.00	123,811.42	37.72%	204,388.58

These reports are provided on a cash basis and are intended for internal use only.

**LEHIGH ACRES FIRE CONTROL RESCUE DISTRICT
BREAKDOWN OF ACCOUNTS
FOR THE SIXTH
MONTH ENDING MARCH 31, 2007**

	PERIOD TO DATE			YEAR TO DATE		Budget Variance
	Actual	%	Annual Budget	Actual	%	
3480 PROMOTIONAL	(120.00)	-0.48%	25,000.00	1,293.57	5.17%	23,706.43
3490 OTHER CURRENT CHGS & OBLIGATIONS						
3491 Motel/Travel/Per Diem	170.26	0.68%	25,000.00	4,751.95	19.01%	20,248.05
3492 Training	1,005.00	1.01%	100,000.00	34,736.45	34.74%	65,263.55
3493 Administrative/Board	157.88	1.32%	12,000.00	5,798.69	48.32%	6,201.31
3494 Administrative/Elections	-	0.00%	24,000.00	-	0.00%	24,000.00
3495 Administrative/Office	2,252.17	8.44%	26,700.00	26,103.64	97.77%	596.36
3496 Contingencies	-	0.00%	515,000.00	10,458.06	2.03%	504,541.94
Total Other Current Chgs & Obligations	3,585.31	0.51%	702,700.00	81,848.79	11.65%	620,851.21
3510 OFFICE	1,574.61	4.50%	35,000.00	17,218.26	49.20%	17,781.74
3520 DEPARTMENT SUPPLIES						
3521 Department Supplies	6,725.88	7.87%	85,500.00	24,679.61	28.87%	60,820.39
3522 Paramedic Supplies	13,099.38	13.10%	100,000.00	73,873.88	73.87%	26,126.12
3523 Gas/Oil	6,769.36	3.38%	200,000.00	48,369.45	24.18%	151,630.65
3524 Uniforms	8,754.00	5.27%	166,250.00	69,436.78	41.77%	96,813.22
3525 Propane	-	0.00%	10,000.00	1,541.33	15.41%	8,458.67
3526 Computer Supplies	454.22	2.27%	20,000.00	1,836.93	9.18%	18,163.07
3527 Prevention Supplies	-	0.00%	5,000.00	3,617.00	72.34%	1,383.00
3528 Janitorial Supplies	1,277.35	6.39%	20,000.00	6,139.80	30.70%	13,860.20
3529 Training Supplies	1,040.44	5.65%	18,400.00	8,516.97	46.29%	9,883.03
3530 Shop Supplies	11.94	0.13%	9,000.00	2,256.59	25.07%	6,743.41
Total Department Supplies	38,132.57	0.44	634,150.00	240,268.34	37.89%	393,881.66
6600 CAPITAL						
6620 Buildings	-	0.00%	-	-	0.00%	-
6630 Improvements/Other	-	0.00%	35,000.00	-	0.00%	35,000.00
6640 Machinery and Equipment	49,299.79	15.09%	326,600.00	87,254.02	26.72%	239,345.98
6641 Grants	-	-	-	-	-	-
6642 Impact Fees	(18,810.17)	-0.35%	5,318,333.00	676,772.79	12.73%	4,641,560.21
6643 Computers	-	0.00%	140,300.00	34,046.98	24.27%	106,253.02
6644 Future Growth Fund	2,190.34	1.00%	220,000.00	18,804.62	8.55%	201,195.38
6645 Vehicles	43,330.10	2.08%	2,085,000.00	48,112.20	2.31%	2,036,887.80
6650 Const. In Progress	590,003.07	7.38%	8,000,000.00	1,883,043.07	23.54%	6,116,956.93
Total Capital Outlay	666,013.13	4.13%	16,125,233.00	2,748,033.68	17.04%	13,377,199.32
7700 DEBT SERVICE						
7710 Principal	-	0.00%	-	-	0.00%	-
7720 Interest on Loans	-	0.00%	-	-	0.00%	-
7730 Interest on Credit Line	-	0.00%	3,000.00	-	0.00%	3,000.00
Total Debt Service	-	0.00%	3,000.00	-	0.00%	3,000.00
9900 RESERVES	-	0.00%	3,262,692.00	-	0.00%	3,262,692.00
9905 DISASTER RESERVES	-	0.00%	1,000,000.00	-	0.00%	-
Total Operating Expenditures	2,078,900.06	5.73%	36,289,863.00	9,391,809.08	25.88%	25,898,180.34

These reports are provided on a cash basis and are intended for internal use only.

Lehigh Acres Fire Control and Rescue District
 Lehigh Acres , Florida 33972
 Reconciliation of Accounts
 March 31, 2007

Page 1

GENERAL CHECKING BANK ACCOUNT:

Balance	March 1, 2007		\$	491,837.87
<u>Income:</u>				\$ 1,096,181.91
Ad Valorem Taxes:		\$	996,278.43	
Interest		\$	-	
Donations:		\$	-	
Inspection Fees:		\$	2,620.00	
User Fees:		\$	91,172.54	
Suppression Fees		\$	61.00	
William Ziegler Account		\$	-	
Miscellaneous Income:		\$	5,659.94	
Report Copies:	\$ 2.00			
Records Request	\$ 45.00			
Wire Transfer Fee	\$ 50.00			
GRIT Payment	\$ 5,562.94			
Proceeds from Insurance:			-	
Prevention Fees & Sales:		\$	390.00	
<u>Reimbursements:</u>				\$ 3,065.78
	<u>Line Item</u>			
CPR	522-3480	\$	160.00	
Sales Tax Payable	202-0400	\$	66.65	
Uniforms	522-3524	\$	387.00	
Sweatshirts	202-0200	\$	710.10	
Overtime	522-1140	\$	919.03	
Alltel Rebates	522-3410	\$	800.00	
Hilton Dayton Beach	522-3491	\$	6.00	
Pcolar - Per Diem	522-3491	\$	17.00	
<u>Health Insurance:</u>				\$ 2,138.94
	Bartley		423.98	
	Cardoza		296.88	
	Temple		728.38	
	MacArty		689.70	
	DeSanto		-	
<u>Transfers:</u>				
	Net Money Market	\$	(107,784.35)	\$ (107,784.35)
<u>Checks:</u>				\$ (983,792.00)
Accounts Payable (see accompanying check list):		\$	(458,901.62)	
Ambulance Refunds:		\$	(3,320.93)	
Payroll:		\$	(521,569.45)	
<u>Payroll tax deposits:</u>				\$ (276,861.27)
<u>Retirement Contribution:</u>				\$ (110,848.76)
<u>Adjusting entries:</u>				\$ (458.60)
Ending balance :	March 31, 2007		\$	<u>113,479.52</u>

Lehigh Acres Fire Control and Rescue District
Accounts Payable and Ambulance Refund Check Register
March 31, 2007

CHECK NUMBER	CHECK DATE	NAME	CHECK AMOUNT
040046	3/6/2007	ALLTEL	\$ 2,555.38
040047	3/6/2007	American Messaging	\$ 150.97
040048	3/6/2007	Larry Arfmann	\$ 506.26
040049	3/6/2007	J. FRANK AVEY, P.A.	\$ 404.00
040050	3/6/2007	Bouchard Insurance	\$ 834.00
040051	3/6/2007	Bound Tree Medical, LLC	\$ 9,982.77
040052	3/6/2007	Cingular Wireless	\$ 11.49
040053	3/6/2007	Comcast	\$ 100.00
040054	3/6/2007	Computers Plus of SWFL, Inc.	\$ 4.42
040055	3/6/2007	CRS Technology	\$ 157.50
040056	3/6/2007	Crystal Springs Water Co.	\$ 50.80
040057	3/6/2007	CS Service Experts	\$ 406.08
040058	3/6/2007	DIRECTV	\$ 37.11
040059	3/6/2007	Edison Insurance Agency, Inc.	\$ 2.00
040060	3/6/2007	Embarq	\$ 49.43
040061	3/6/2007	Florida Governmental Utility	\$ 142.67
040062	3/6/2007	FIREHOUSE	\$ 30.00
040063	3/6/2007	Florida Spring & Axle Service	\$ 2,308.45
040064	3/6/2007	Florida MVR Services	\$ 62.20
040065	3/6/2007	Gold Cup Coffee Service Inc.	\$ 79.60
040066	3/6/2007	Grease Monkey	\$ 129.42
040067	3/6/2007	Harrington Pharmacy	\$ 55.00
040068	3/6/2007	Jems	\$ 29.97
040069	3/6/2007	Lehigh Auto Parts, Inc.	\$ 588.62
040070	3/6/2007	Medical Department Store	\$ 3,800.00
040071	3/6/2007	Medtronic Emergency Response	\$ 1,626.90
040072	3/6/2007	Nextel Communications	\$ 574.96
040073	3/6/2007	Dale Pinheiro	\$ 225.00
040074	3/6/2007	Robert Pittler	\$ 225.00
040075	3/6/2007	Praxair Distribution SE, LLC	\$ 86.53
040076	3/6/2007	Publix Super Markets, Inc.	\$ 103.88
040077	3/6/2007	Ronicki Plumbing	\$ 75.00
040078	3/6/2007	Ryan Petroleum	\$ 3,427.62
040079	3/6/2007	Signs in One Day	\$ 90.00
040080	3/6/2007	Sun Belt Medical/Emergi-Source	\$ 1,027.15
040081	3/6/2007	Ten-8 Fire Equipment Inc.	\$ 1,465.50
040082	3/6/2007	Waste Management	\$ 566.19
040083	3/6/2007	The Wireless Store	\$ 144.42
040084	3/6/2007	WTEC	\$ 617.04
040085	3/6/2007	Grainger	\$ 1,577.30
040086	3/13/2007	A-1 Septic Tank Service	\$ 225.00
040087	3/13/2007	Vision Ace	\$ 431.56
040088	3/13/2007	Bound Tree Medical, LLC	\$ 4,524.01
040089	3/13/2007	Ambulance Refund	\$ 459.00
040090	3/13/2007	CRS Technology	\$ 4,431.25
040091	3/13/2007	CS Service Experts	\$ 314.50
040092	3/13/2007	Diversified Inspections	\$ 1,032.73
040093	3/13/2007	Embarq	\$ 1,822.57
040094	3/13/2007	Emergency Medical Products	\$ 215.80
040095	3/13/2007	Florida Governmental Utility	\$ 539.50
040096	3/13/2007	Ambulance Refund	\$ 37.13
040097	3/13/2007	Fisher Scientific	\$ 80.00
040098	3/13/2007	Ambulance Refund	\$ 331.00
040099	3/13/2007	Henry Schein Inc.	\$ 5,375.29
040100	3/13/2007	Ambulance Refund	\$ 22.20
040101	3/13/2007	Ambulance Refund	\$ 99.61
040102	3/13/2007	Laerdal Medical Corporation	\$ 1,040.44
040103	3/13/2007	Law Enforcement Supply Co. Inc	\$ 1,299.00
040104	3/13/2007	Lee County Electric Coop.	\$ 147.83
040105	3/13/2007	Joseph Lemmons	\$ 5,000.00
040106	3/13/2007	Lewis, Longman & Walker P.A.	\$ 1,758.90
040107	3/13/2007	Konica Minolta Business	\$ 66.75

Lehigh Acres Fire Control and Rescue District
 Accounts Payable and Ambulance Refund Check Register
 March 31, 2007

CHECK NUMBER	CHECK DATE	NAME	CHECK AMOUNT
040108	3/13/2007	Konica Minolta Business	\$ 143.06
040109	3/13/2007	Morganelli & Associates	\$ 221.43
040110	3/13/2007	Municipal Equipment Company	\$ 40.00
040111	3/13/2007	N & N Supply	\$ 786.08
040112	3/13/2007	Nationwide Retirement Solution	\$ 8,519.16
040113	3/13/2007	NAFECO Inc.	\$ 633.06
040114	3/13/2007	Nokomis Fire Academy	\$ 450.00
040115	3/13/2007	Office Depot	\$ 1,115.80
040116	3/13/2007	Our Creations Florist	\$ 56.00
040117	3/13/2007	Praxair Distribution SE, LLC	\$ 1,107.80
040118	3/13/2007	Rider's Trailers	\$ 375.00
040119	3/13/2007	ScreenPrint Plus, Inc.	\$ 209.20
040120	3/13/2007	Sprint	\$ 61.65
040121	3/13/2007	Stryker Sales Corporation	\$ 35,040.12
040122	3/13/2007	Sun Belt Medical/Emergi-Source	\$ 1,470.84
040123	3/13/2007	SunTrust BankCard, N.A.	\$ 375.98
040124	3/13/2007	Suncoast Schools Fed. Cr. Un.	\$ 44,749.01
040125	3/13/2007	SW Florida Prof. Firefighters	\$ 4,559.17
040127	3/13/2007	Voyager Fleet Systems, Inc.	\$ 214.69
040128	3/13/2007	Worthington Sprinklers	\$ 473.52
040129	3/20/2007	AARP	\$ 85.46
040130	3/20/2007	Bouchard Insurance	\$ 6,506.00
040131	3/20/2007	Cap City USA	\$ 1,495.00
040132	3/20/2007	Cingular Wireless	\$ 3.97
040134	3/20/2007	CRS Technology	\$ 956.25
040135	3/20/2007	Crystal Springs Water Co.	\$ 60.34
040136	3/20/2007	Elite Fire & Safety Equipment	\$ 2,600.00
040137	3/20/2007	Embarq Communications, Inc.	\$ 60.95
040138	3/20/2007	First Floridian	\$ 305.60
040139	3/20/2007	Ambulance Refund	\$ 11.17
040140	3/20/2007	Hall-Mark Fire Apparatus, Inc.	\$ 183.93
040141	3/20/2007	Home Depot Credit Services	\$ 246.07
040142	3/20/2007	House of Ladders	\$ 409.00
040143	3/20/2007	Ambulance Refund	\$ 6.85
040144	3/20/2007	Lee County Electric Coop.	\$ 1,449.77
040145	3/20/2007	Medical Department Store	\$ 2,607.45
040146	3/20/2007	MetLife SBC	\$ 7,827.22
040147	3/20/2007	Overhead Door Co of Ft Myers	\$ 349.30
040148	3/20/2007	Praxair Distribution SE, LLC	\$ 254.24
040149	3/20/2007	Richard W. Pringle, P.A.	\$ 10,637.50
040150	3/20/2007	Roberts Company Inc.	\$ 93.50
040151	3/20/2007	Ryan Petroleum	\$ 3,127.05
040152	3/20/2007	Sam Galloway Ford	\$ 21,354.50
040153	3/20/2007	Sam's Club	\$ 1,402.02
040154	3/20/2007	ScreenPrint Plus, Inc.	\$ 1,540.00
040155	3/20/2007	Staff Development	\$ 40.00
040156	3/20/2007	Standard Insurance Company	\$ 10,683.99
040157	3/20/2007	Standard Insurance Company	\$ 2,194.45
040158	3/20/2007	Sun Belt Medical/Emergi-Source	\$ 1,692.00
040159	3/20/2007	T & M Portable Restrooms, Inc.	\$ 918.00
040160	3/20/2007	Ten-8 Fire Equipment Inc.	\$ 1,203.00
040161	3/20/2007	United Healthcare	\$ 114,168.67
040162	3/20/2007	Vance's Automotive Center	\$ 76.00
040163	3/20/2007	WTEC	\$ 82.50
040164	3/23/2007	COBRASERV	\$ 371.65
040165	3/26/2007	Callaghan Tire	\$ 298.36
040166	3/26/2007	Sal Chiazelli	\$ 36.00
040167	3/26/2007	CS Service Experts	\$ 1,988.00
040168	3/26/2007	Embarq	\$ 219.38
040169	3/26/2007	Emergency Medical Services	\$ 1,375.00
040170	3/26/2007	Florida Governmental Utility	\$ 116.13
040171	3/26/2007	Hall-Mark Fire Apparatus, Inc.	\$ 465.60
040172	3/26/2007	Lee County BOCC	\$ 54.00
040173	3/26/2007	Lee County Electric Coop.	\$ 1,362.23
040174	3/26/2007	Konica Minolta Business	\$ 61.69

2 or 3?

Lehigh Acres Fire Control and Rescue District
 Accounts Payable and Ambulance Refund Check Register
 March 31, 2007

<u>CHECK NUMBER</u>	<u>CHECK DATE</u>	<u>NAME</u>	<u>CHECK AMOUNT</u>
040175	3/26/2007	Nationwide Retirement Solution	\$ 8,659.16
040176	3/26/2007	Preferred Governmental	\$ 38,841.48
040177	3/26/2007	Progressive Business Publicat	\$ 195.50
040178	3/26/2007	Radiology Regional Center	\$ 92.00
040179	3/26/2007	R & L Carriers, Inc.	\$ 108.67
040180	3/26/2007	Suncoast Schools Fed. Cr. Un.	\$ 43,330.69
040181	3/26/2007	Thompson Publishing Group, Inc	\$ 453.50
040182	3/26/2007	United States Treasury	\$ 150.00
040183	3/26/2007	WTEC	\$ 150.00
040184	3/30/2007	Ambulance Refund	\$ 68.48
040185	3/30/2007	Ambulance Refund	\$ 354.10
040186	3/30/2007	Ambulance Refund	\$ 385.12
040187	3/30/2007	Ambulance Refund	\$ 72.15
040188	3/30/2007	Ambulance Refund	\$ 283.25
040189	3/30/2007	Ambulance Refund	\$ 572.18
040190	3/30/2007	Ambulance Refund	\$ 217.63
040191	3/30/2007	Ambulance Refund	\$ 10.00
REPORT TOTAL			\$ 459,089.97

Lehigh Acres Fire Control and Rescue District
Lehigh Acres , Florida 33972
Reconciliation of Accounts
March 31, 2007
Page 2

MONEY MARKET BANK ACCOUNT:

Balance	March 1, 2007		\$	10,595,948.18
Deposits			\$	-
Transfers In:	From Checking	\$	493,661.56	\$ 493,661.56
	From Impact Fees	\$	-	
	From Grant Account			
Transfers Out:		\$	(385,877.21)	\$ (385,877.21)
Interest				47,270.98
Payments:			\$	-
Ending balance :	March 31, 2007		\$	<u>10,751,003.51</u>

IMPACT FEE MONEY MARKET BANK ACCOUNT:

Balance	March 1, 2007		\$	4,098,411.53
Deposits			\$	-
Account Analysis Fee			\$	-
Transfer			\$	-
Interest			\$	17,432.28
Ending balance :	March 31, 2007		\$	<u>4,115,843.81</u>

PREMIUM CHECKING CONSTRUCTION LOAN ACCOUNT:

Balance per general ledger:	March 1, 2007		\$	6,582,290.11
Deposits:			\$	-
Checks:			\$	(6,210.78)
Wire Transfers:			\$	(583,792.29)
Interest:			\$	27,149.53
Ending balance per G/L:	March 31, 2007		\$	<u>6,019,436.57</u>

Lehigh Acres Fire Control and Rescue District
Construction Loan Check Register
March 31, 2007

<u>CHECK NUMBER</u>	<u>CHECK DATE</u>	<u>NAME</u>	<u>CHECK AMOUNT</u>
000133	3/6/2007	Gora McGahey Associates	1,067.28
000134	3/6/2007	Gora McGahey Associates	2,250.00
000135	3/13/2007	Florida Governmental Utility	305
000136	3/20/2007	AIM Engineering & Surveying	2,588.50
REPORT TOTAL			\$ <u>6,210.78</u>

Lehigh Acres Fire Control and Rescue District Liabilities March 31, 2007

Current Liabilities:

Accounts Payable

Miscellaneous Payables (See Breakdown next pg)	\$	(179,212.78)
------------------------------------------------	----	--------------

Long Term Liabilities:

Construction Loan

(Principal & Interest Payment Due 04/01/2007 - Rate 5.15%)

	\$	8,000,000.00
Total Principal Payments	\$	(30,500.00)
Principal Balance @ 03/31/2007	\$	<u>7,969,500.00</u>

Total Long Term Liabilities	\$	7,969,500.00
------------------------------------	-----------	---------------------

Pmt Due Date	Principal	Interest	Total Payment
4/1/2007	\$236,500	\$102,607.31	\$ 339,107.31
7/1/2007	\$133,500	\$99,562.38	\$ 233,062.38

Lehigh Acres Fire Control and Rescue District
Accounts Payable Breakdown
March 31, 2007

	Vendor Name	Balance Due Vendor	Description
1	Florida Department of Revenue	\$ (179,226.41)	Retirement Contribution
2	Office Max	\$ 13.63	Office Supplies
	Total	<u>\$ (179,212.78)</u>	

Lehigh Acres Fire Control and Rescue District
Ambulance User Fees Billed & Outstanding
March 31, 2007

	\$	846,931.32
User Fees Outstanding @ 10/30/06 (Audited)	\$	779,827.00
User Fees Billed this year	\$	<u>1,626,758.32</u>
Total User Fees Billed @ 03/31/07		
Less: User Fees Cash Received Net of Refunds @ 03/31/07	\$	(462,170.89)
Outstanding User Fees before W/O's, Refunds & Allowance @ 03/31/07	\$	1,164,587.43
Governmental Contractual Write-Offs	\$	(82,240.24)
Less: Allowance for Doubtful Accounts	\$	<u>(253,332.86)</u>
Net User Fees Outstanding @ 03/31/07	\$	<u><u>829,014.33</u></u>

LEHIGH ACRES FIRE CONTROL & RESCUE DISTRICT

FIRE SUPPRESSION DIVISION RESPONSE TOTAL

MARCH, 2007

		YTD			YTD
Shift A:	223	620	Sunday	70	247
Shift B:	241	610	Monday	85	260
Shift C:	211	598	Tuesday	73	251
			Wednesday	101	273
Total Responses:	675	1828	Thursday	118	262
			Friday	103	255
Average Response Time:	5.39 MINUTES		Saturday	125	280

Total 675 1828

TYPE OF SITUATION FOUND

TOTAL INCIDENTS

YTD

100	FIRE, OTHER	8	19
111	BUILDING FIRE	5	11
112	FIRE STRUCTURES OTHER THAN IN A BUILDING	0	1
113	COOKING FIRE, CONFINED TO CONTAINER	3	7
114	CHIMNEY OR FLUE FIRE	0	0
118	TRASH OR RUBBISH FIRE, CONTAINED	1	1
120	FIRE IN MOBILE PROP. USED AS A FIXED STRUC., OTHER	0	0
123	FIRE IN PORTABLE BUILDING, FIXED LOCATION	0	0
130	MOBILE PROPERTY (VEHICLE) FIRE, OTHER	2	3
131	PASSENGER VEHICLE FIRE	7	15
132	ROAD FREIGHT OR TRANSPORT VEHICLE FIRE	0	1
134	WATER, VEHICLE FIRE	0	0
136	SELF-PROPELLED MOTOR HOME OR RECREATIONAL VEHICLE	0	0
137	CAMPER OR RECREATIONAL VEHICLE (RV) FIRE	0	0
138	OFF ROAD VEHICLE OR HEAVY EQUIPMENT FIRE	0	1
140	NATURAL VEGETATION FIRE, OTHER	14	15
141	FOREST, WOODS OR WILDLAND FIRE	5	5
142	BRUSH, OR BRUSH AND GRASS MIXTURE FIRE	22	36
143	GRASS FIRE	20	24
150	OUTSIDE RUBBISH FIRE, OTHER	1	4
151	OUTSIDE RUBBISH, TRASH OR WASTE FIRE	7	15
152	GARBAGE DUMP OR SANITARY LANDFILL FIRE	0	0
153	CONSTRUCTION OR DEMOLITION LANDFILL FIRE	0	0
154	DUMPSTER OR OTHER OUTSIDE TRASH RECEPTACLE FIRE	3	3
160	SPECIAL OUTSIDE FIRE, OTHER	5	5
161	OUTSIDE STORAGE FIRE	0	0
162	OUTSIDE EQUIPMENT FIRE	0	1
163	OUTSIDE GAS OR VAPOR COMBUSTION EXPLOSION	0	0
170	CULTIVATED VEGETATION, CROP FIRE, OTHER	0	0
223	AIR OR GAS RUPTURE OF PRESURE OR PROCESS VESSEL	0	0
240	EXPLOSION (NO FIRE), OTHER	0	0
251	EXCESSIVE HEAT. SCORCH BURNS WITH NO IGNITION	0	0
300	RESCUE, EMERGENCY MEDICAL CALL (EMS) CALL, OTHER	236	698
311	MEDICAL ASSIST, ASSIST EMS CREW	33	64
321	EMS CALL, EXCLUDING VEHICLE ACCIDENT WITH INJURY	170	509
322	VEHICLE ACCIDENT WITH INJURIES	13	46
323	MOTOR VEHICLE/PEDESTRIAN ACCIDENT (MV PED)	1	7
324	MOTOR VEHICLE ACCIDENT WITH NO INJURIES	5	35
331	LOCK-IN	2	4
340	SEARCH, OTHER	0	0
350	EXTRICATION, RESCUE, OTHER	1	2
352	EXTRICATION OF VICTIM(S) FROM VEHICLE	0	2
357	EXTRICATION OF VICTIM(S) FROM MACHINERY	1	1
360	WATER & ICE RELATED RESCUE, OTHER	0	0
361	SWIMMING/RECREATIONAL WATER AREAS RESCUE	0	0
381	RESCUE OR EMS STANDBY	0	2

400	HAZARDOUS CONDITION, OTHER	2	2
410	FLAMMABLE GAS OR LIQUID CONDITION, OTHER	0	1
411	GASOLINE OR OTHER FLAMMABLE LIQUID SPILL	1	1
412	GAS LEAK (NATURAL GAS OR LPG)	1	3
413	OIL OR OTHER COMBUSTIBLE LIQUID SPILL	0	3
424	CARBON MONOXIDE INCIDENT	1	1
440	ELECTRICAL WIRING/EQUIPMENT PROBLEM, OTHER	1	1
441	HEAT FROM SHORT CIRCUIT (WIRING), DEFECTIVE/WORN	0	0
442	OVERHEATED MOTOR	0	0
443	LIGHT BALLAST BREAKDOWN	0	1
444	POWER LINE DOWN	0	3
445	ARCING, SHORTED ELECTRICAL EQUIPMENT	0	0
451	BIOLOGICAL HAZARDOUS, CONFIRMED OR SUSPECTED	0	0
460	ACCIDENT, POTENTIAL ACCIDENT, OTHER	0	0
461	BUILDING OR STRUCTURE WEAKENED OR COLLAPSED	0	0
462	AIRCRAFT STANDBY	0	0
463	VEHICLE ACCIDENT, GENERAL CLEANUP	0	0
480	ATTEMPTED BURINING, ILLEGAL ACTION, OTHER	0	0
500	SERVICE CALL, OTHER	2	3
510	PERSON IN DISTRESS, OTHER	3	4
511	LOCK-OUT	2	2
531	SMOKE OR ODOR REMOVAL	3	5
550	PUBLIC SERVICE ASSISTANCE	4	6
551	ASSIST POLICE OR OTHER GOVERNMENTAL AGENCY	0	0
552	POLICE MATTER	0	0
553	PUBLIC SERVICE	1	3
554	ASSIST INVALID	0	0

TYPE OF SITUATION FOUND

555	DEFECTIVE ELEVATOR, NO OCCUPANTS	0	0
561	UNAUTHORIZED BURNING	5	13
571	COVER ASSIGNMENT, STANDBY, MOVEUP	0	0
600	GOOD INTENT CALL, OTHER	21	47
611	DISPATCHED & CANCELED EN ROUTE	2	11
621	WRONG LOCATION	1	1
622	NO INCIDENT FOUND ON ARRIVAL AT DISPATCH ADDRESS	0	1
631	AUTHORIZED CONTROLLED BURNING	0	2
632	PRESCRIBED FIRE	0	2
650	STEAM, OTHER GAS MISTAKEN FOR SMOKE, OTHER	0	0
651	SMOKE SCARE, ODOR OF SMOKE	0	1
652	STEAM, VAPOR, FOG OR DUST THOUGHT TO BE SMOKE	0	2
661	EMS CALL, PARTY TRANSPORTED BY NON-FIRE AGENCY	0	0
671	HAZMAT RELEASE INVESTIGATION W/NO HAZMAT	0	0
700	FALSE ALARM OR FALSE CALL, OTHER	43	111
710	MALICIOUS, MISCHIEVOUS FALSE CALL, OTHER	1	5
711	MUNICIPAL ALARM SYSTEM, Malicious false alarm	1	2
712	DIRECT TIE TO FD, MALICIOUS/FALSE ALARM	0	0
713	TELEPHONE, MALICIOUS FALSE ALARM	0	0
714	CENTRAL STATION, MALICIOUS FALSE ALARM	0	0
715	LOCAL ALARM SYSTEM, MALICIOUS FALSE ALARM	0	1
721	BOMB SCARE - NO BOMB	0	0
730	SYSTEM MALFUNCTION, OTHER	1	3
731	SPRINKLER ACTIVATION DUE TO MALFUNCTION	0	0
732	EXTINGUISHING SYSTEM ACTIVATION DUE TO MALFUNCTION	0	0
733	SMOKE DETECTOR ACTIVATION	2	4
734	HEAT DETECTOR ACTIVATION DUE TO MALFUNCTION	0	0
735	ALARM SYSTEM SOUNDED DUE TO MALFUNCTION	1	5
740	UNINTENTIONAL TRANSMISSION OF ALARM, OTHER	2	7
741	SPRINKLER ACTIVATION, NO FIRE - UNINTENTIONAL	0	0
742	EXTINGUISHING SYSTEM ACTIVATION	0	0
743	SMOKE DETECTOR ACTIVATION, NO FIRE - UNINTENTIONAL	2	18
744	DETECTOR ACTIVATION, NO FIRE - UNINTENTIONAL	2	3
745	ALARM SYSTEM SOUNDED, NO FIRE - UNINTENTIONAL	5	12
746	CARBON MONOXIDE DETECTOR ACTIVATION, NO CO	0	0
814	LIGHTNING STRIKE (NO FIRE)	0	0
900	SPECIAL TYPE OF INCIDENT, OTHER	0	0
911	CITIZEN COMPLAINT	0	1

GRAND TOTALS

675

1828

Calls By Day

Date Range:

(@DTE) in Date (2007, 3, 1) to Date (2007, 3, 31)

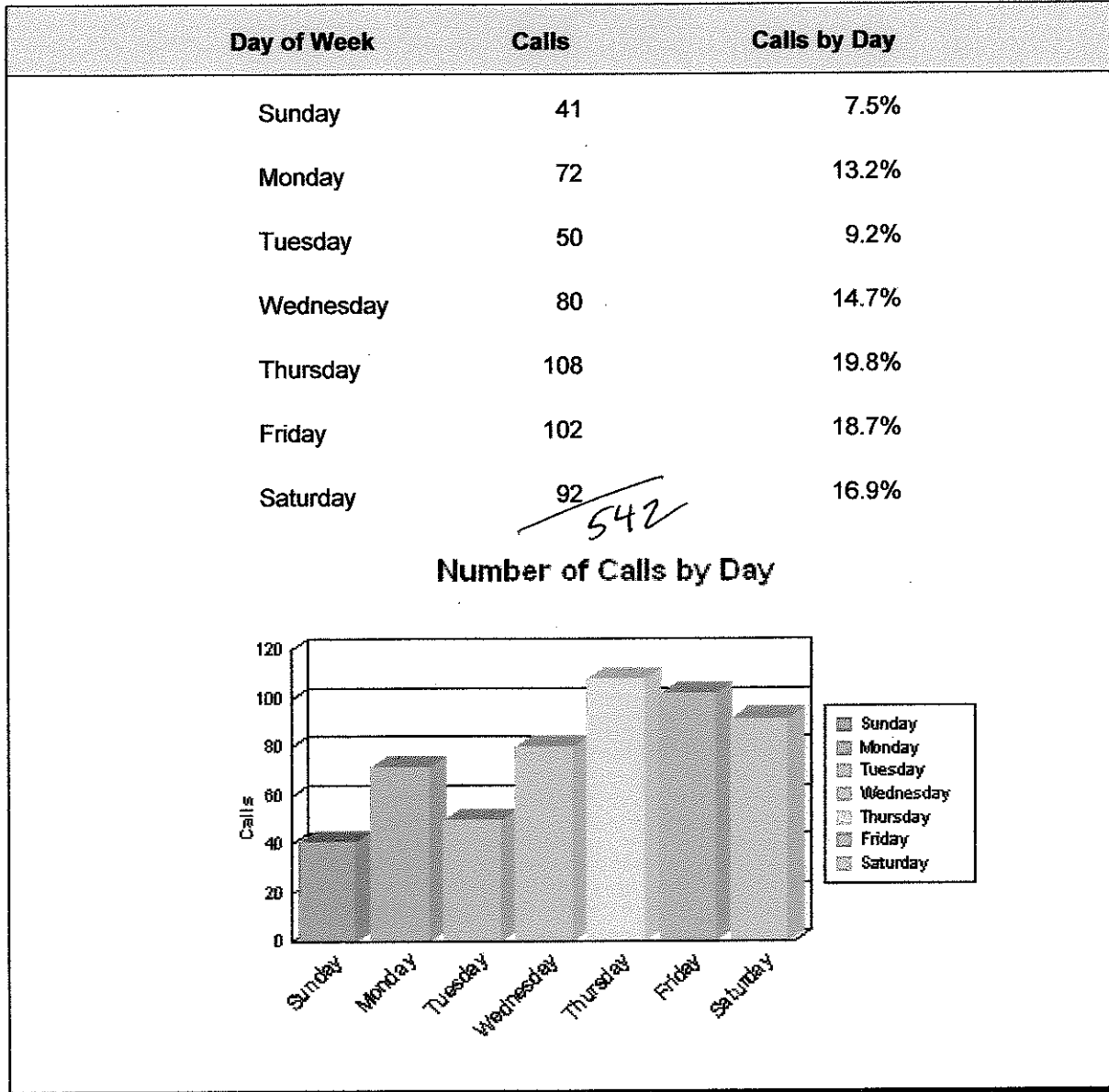

Calls by Unit

(By Time of Day)

Date Range:

{@DTE} in Date (2007. 3. 1) to Date (2007. 3. 31)

PRIME UNIT	Time of Day	Calls
110	00:01 to 03:59	7
	04:00 to 07:59	14
	08:00 to 11:59	12
	12:00 to 15:59	40
	16:00 to 19:59	20
	20:00 to 24:00	18
	120	00:01 to 03:59
04:00 to 07:59		32
08:00 to 11:59		25
12:00 to 15:59		45
16:00 to 19:59		25
20:00 to 24:00		22
130		00:01 to 03:59
	04:00 to 07:59	15
	08:00 to 11:59	21
	12:00 to 15:59	19
	16:00 to 19:59	26
	20:00 to 24:00	23
	170	00:01 to 03:59
04:00 to 07:59		10
08:00 to 11:59		9
12:00 to 15:59		12
16:00 to 19:59		11
20:00 to 24:00		11
180		00:01 to 03:59
	04:00 to 07:59	7
	08:00 to 11:59	10
	12:00 to 15:59	10
	16:00 to 19:59	8
	20:00 to 24:00	12
	210	

Date Range:

{@DTE} m Date (2007. 3. 1) to Date (2007. 3. 31):

PRIME UNIT	Time of Day	Calls
	12:00 to 15:59	7
	16:00 to 19:59	12
	20:00 to 24:00	2
220		
	04:00 to 07:59	3
	08:00 to 11:59	6
	12:00 to 15:59	2
	20:00 to 24:00	1
230		
	08:00 to 11:59	4
	12:00 to 15:59	1
	16:00 to 19:59	6
250		
	16:00 to 19:59	1
SYSTEM TOTAL		543

Number of Calls Per Period

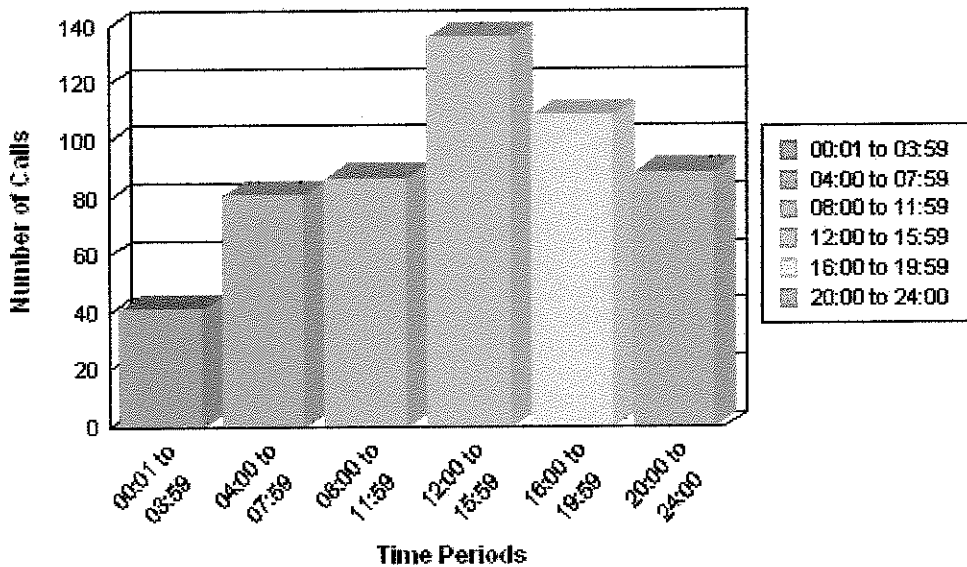

Transports by Destination

(Summary)

Date Range:

{@DTE} in Date (2007, 3, 1) to Date (2007, 3, 31)

Destination	Transports	%	
	1	0%	
CCH	4	1%	
GCH	20	6%	
LMH	28	9%	
LMHP	33	10%	
LRMC	179	56%	
SWFRMC	54	17%	
SYSTEM TOTAL	TOTAL TRANSPORTS	319	100%

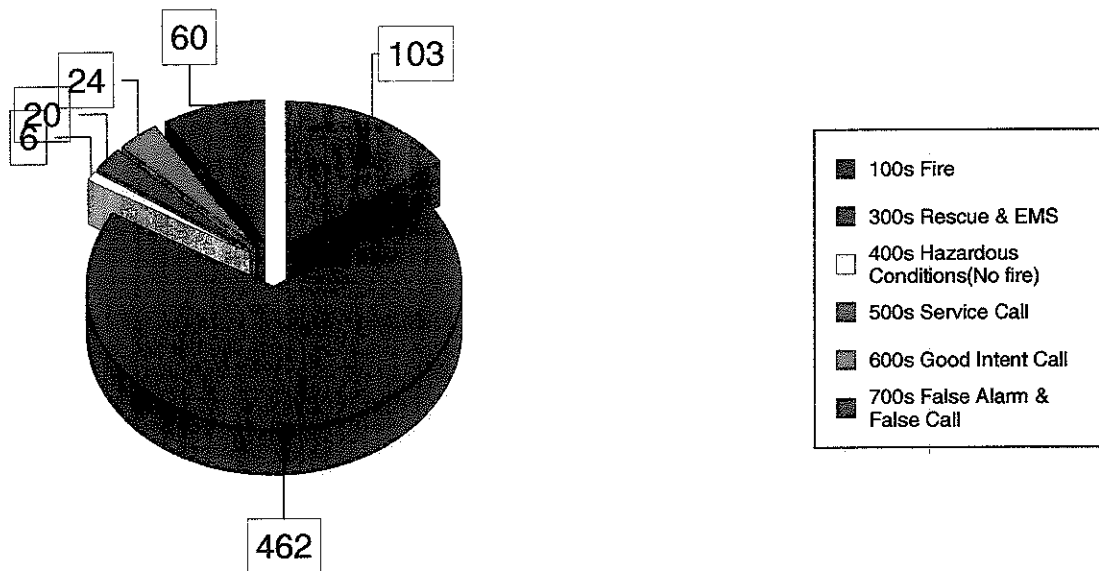

Graphed Items are sorted by Incident Type

Type Of Incident:	Total Of Incidents:	Percentage Value:
100 Series-Fire	103	15.26%
300 Series-Rescue & EMS	462	68.44%
400 Series-Hazardous Conditions(No fire)	6	0.89%
500 Series-Service Call	20	2.96%
600 Series-Good Intent Call	24	3.56%
700 Series-False Alarm & False Call	60	8.89%

Grand Total: 675

Type Of Incident Most Frequent: 300 Series-Rescue & EMS

Print Date: 4/2/2007

Incident Reporting by Month

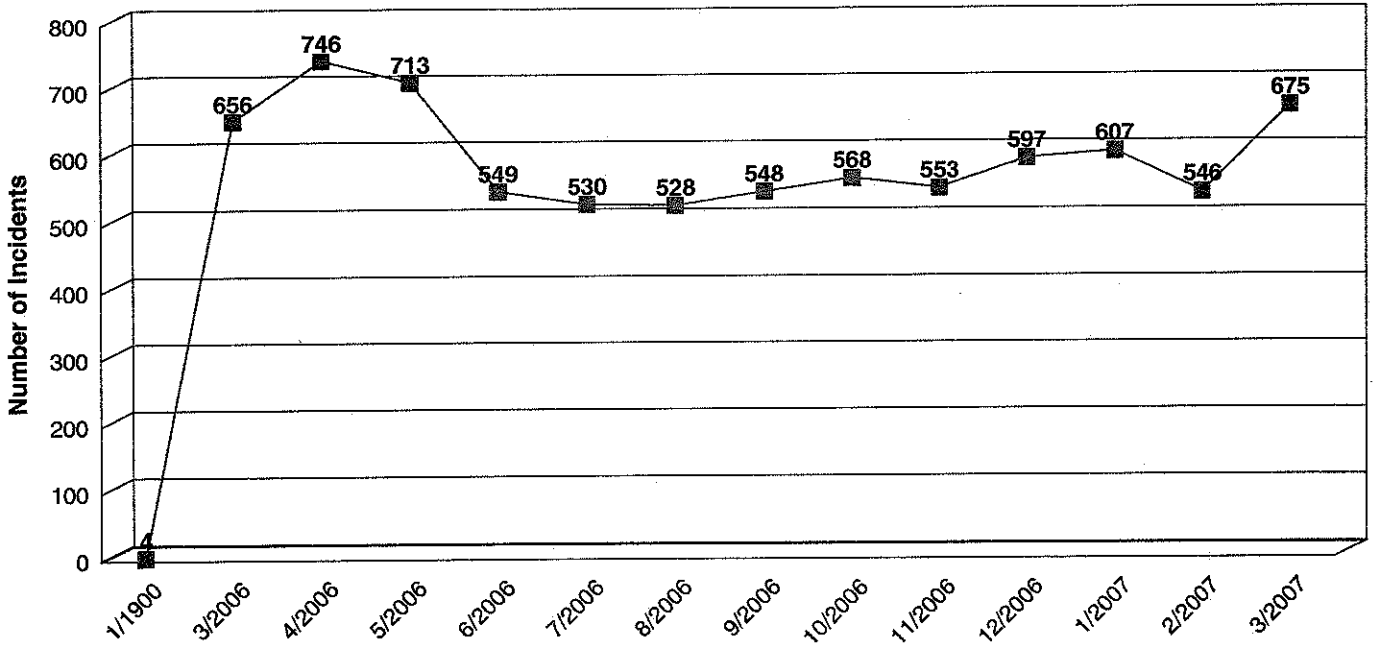

Plotted points on Graph read from left to right.

Period:	# of Incidents:
1/1900	4
3/2006	656
4/2006	746
5/2006	713
6/2006	549
7/2006	530
8/2006	528
9/2006	548
10/2006	568
11/2006	553
12/2006	597
1/2007	607
2/2007	546
3/2007	675

Print Date: 4/2/2007

Total Incidents: 7,820

PATIENT CONTACTS

CALENDAR YEAR TO DATE

2007

EMS PATIENTS

EMS PATIENTS

EMS PATIENTS

JAN	2005	453	2006	493	2007	545
FEB	2005	456	2006	490	2007	528
MAR	2005	548	2006	656	2007	543
APR	2005	499	2006	492	2007	0
MAY	2005	481	2006	480	2007	0
JUN	2005	427	2006	478	2007	0
JUL	2005	477	2006	507	2007	0
AUG	2005	480	2006	591	2007	0
SEP	2005	476	2006	549	2007	0
OCT	2005	523	2006	596	2007	0
NOV	2005	523	2006	537	2007	0
DEC	2005	542	2006	581	2007	0

2005 YTD: 5885

2006 YTD: 6450

2007 YTD: 1616

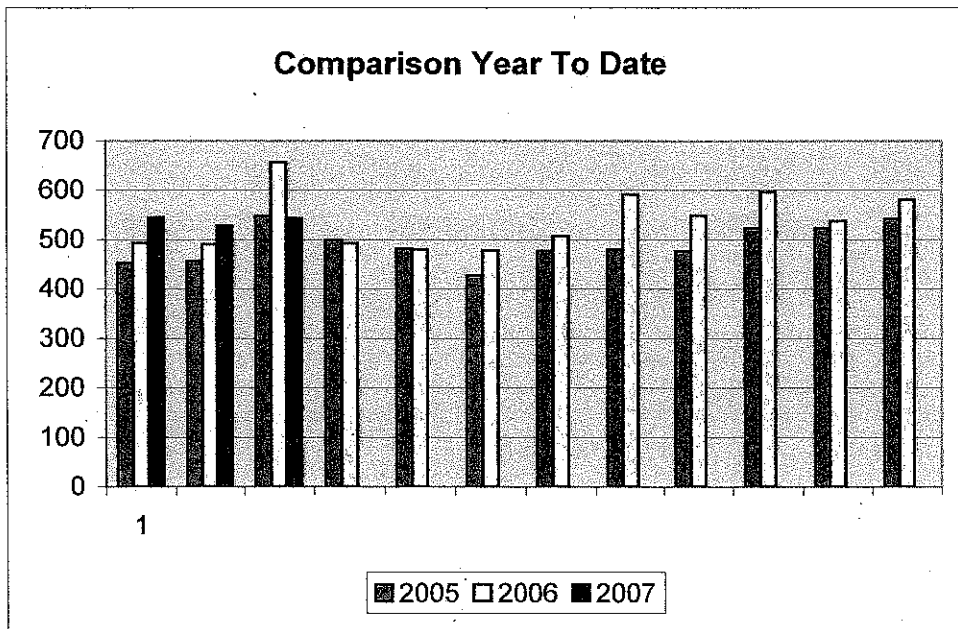

Increase from 2005 to 2006: 19.70%
 Decrease from 2006 to 2007: 20.80%

03/01/2007

Monthly Inspection Receipt Report

03/31/2007

Hydrant Flow Test	5	@	\$60.00	each	=	\$300.00
Water Main Tap	1	@	\$80.00	each	=	\$80.00
Fire Main Underground	1	@	\$75.00	each	=	\$75.00
Fire Sprinkler (per zone) x hr	4	@	\$60.00	each	=	\$240.00
Fire Detection \$20 min, \$2 per device	20	@	\$2.00	each	=	\$40.00
1 hr. Fire Partition (per layer)	15	@	\$20.00	each	=	\$300.00
2 hr. Fire Walls, per inspection hr.	4	@	\$50.00	each	=	\$200.00
4 hr. Fire Walls, per inspection hr.	1	@	\$100.00	each	=	\$100.00
Building Permit Final	8	@	\$45.00	each	=	\$360.00
Carnival/Amusement	1	@	\$100.00	each	=	\$100.00
Temporary Structures	1	@	\$35.00	each	=	\$35.00
C.O. Inspection	7	@	\$35.00	each	=	\$245.00
Annual Inspection (existings)	44	@	\$15.00	each	=	\$660.00
H.R.S.	9	@	\$55.00	each	=	\$495.00
Sprinkler Upcharge	6	@	\$10.00	each	=	\$60.00
Alarm System Upcharge	11	@	\$10.00	each	=	\$110.00
Fire Wall Upcharge	8	@	\$5.00	each	=	\$40.00
Hood Suppression Upcharge	8	@	\$5.00	each	=	\$40.00
Knox Box W/O Tamper	1	@	\$195.00	each	=	\$195.00
Fire Alarm Activation	16	@	\$20.00	each	=	\$320.00
Tax - Knox Box W/O Tamper	1	@	\$11.70	each	=	\$11.70

04/06/2007

Page 1 of 1

Monthly Total**\$4,006.70**

Fiscal Inspection Receipt Report

Hydrant Flow Test	37	@	\$60.00	each	=	\$2,220.00
Water Main Tap	3	@	\$80.00	each	=	\$240.00
Fire Main Underground	4	@	\$75.00	each	=	\$300.00
Fire Main Flush	3	@	\$75.00	each	=	\$225.00
Fire Sprinkler (per zone) x hr	17	@	\$60.00	each	=	\$1,020.00
Cooking Hood	4	@	\$20.00	each	=	\$80.00
Hood Suppression	3	@	\$20.00	each	=	\$60.00
Fire Detection \$20 min, \$2 per device	431	@	\$2.00	each	=	\$862.00
1 hr. Fire Partition (per layer)	18	@	\$20.00	each	=	\$360.00
2 hr. Fire Walls, per inspection hr.	7	@	\$50.00	each	=	\$350.00
4 hr. Fire Walls, per inspection hr.	8	@	\$100.00	each	=	\$800.00
Building Permit Final	68	@	\$45.00	each	=	\$3,060.00
Carnival/Amusement	3	@	\$100.00	each	=	\$300.00
Burn Site Inspections	23	@	\$50.00	each	=	\$1,150.00
LP Gas Lines (per hr.)	7	@	\$25.00	each	=	\$175.00
Temporary Structures	13	@	\$35.00	each	=	\$455.00
Fire Dampers / Shutters	48	@	\$10.00	each	=	\$480.00
Fuel Tanks (underground)	2	@	\$90.00	each	=	\$180.00
C.O. Inspection	53	@	\$35.00	each	=	\$1,855.00
Annual Inspection (existings)	315	@	\$15.00	each	=	\$4,725.00
H.R.S.	33	@	\$55.00	each	=	\$1,815.00
Health Care Facility	2	@	\$75.00	each	=	\$150.00
Sprinkler Upcharge	61	@	\$10.00	each	=	\$610.00
Alarm System Upcharge	96	@	\$10.00	each	=	\$960.00
Fire Wall Upcharge	111	@	\$5.00	each	=	\$555.00
Hood Suppression Upcharge	38	@	\$5.00	each	=	\$190.00
Knox Box W/O Tamper	4	@	\$195.00	each	=	\$780.00
Entry Gate Switch	1	@	\$90.00	each	=	\$90.00
Fire Alarm Activation	90	@	\$20.00	each	=	\$1,800.00
Tax - Knox Box W/O Tamper	4	@	\$11.70	each	=	\$46.80
Tax - Entry Gate Switch	1	@	\$5.40	each	=	\$5.40
Knox Safe	2	@	\$415.00	each	=	\$830.00
Knox Safe Mounting Kit	2	@	\$85.00	each	=	\$170.00
Tax - Knox Safe	2	@	\$24.90	each	=	\$49.80
Tax - Knox Safe Mounting Kit	2	@	\$5.10	each	=	\$10.20
Freight	1	@	\$60.00	each	=	\$60.00

Plans Reviewed

From 03/01/2007 To 03/31/2007

Date In	Permit Number	Project Name	Review Date	Status	Comments
03/01/2007	COM2007-00127	Cutral Concrete "B" Build Out	03/01/2007	Approved	
03/01/2007	COM2006-03681	Bahathique Restaurant	03/06/2007	Approved	
03/01/2007	COM2007-00449	Lee Blvd Physicians Primary Care	03/06/2007	Approved	
03/01/2007	COM2007-00675	607 Williams Ave Tenant Buildout Suite 3	03/12/2007	Approved	
03/01/2007	COM2006-03440	Eye Centers of Florida	03/07/2007	Approved	
03/01/2007	FIR2007-00183	Lehigh Acres Fire Station #5	03/05/2007	Approved	
03/01/2007	COM2005-03250	Reyreart Mang Group	03/01/2007	Approved	Plumbing Revision Only.
03/01/2007	COM2006-02897	I & E Homes	03/01/2007	Approved	Plumbing Revision Only.
03/01/2007	COM2007-00671	607 Williams Ave Tenant Buildout-Suite 1	03/05/2007	Approved	Fire Sprinkler required by Lee County.
03/01/2007	COM2007-00670	607 Williams Ave Tenant Buildout Suite 2	03/05/2007	Approved	Fire sprinkler required by Lee County.
03/06/2007	COM2007-00649	Lehigh Medical Center	03/12/2007	Approved	
03/06/2007	COM2007-00652	Lehigh Medical Center	03/12/2007	Approved	
03/06/2007	COM2007-00652	Lehigh Medical Center	03/12/2007	Approved	
03/06/2007	COM2007-00648	Lehigh Medical Center	03/12/2007	Approved	
03/06/2007	COM2007-00651	Lehigh Medical Center	03/12/2007	Approved	
03/06/2007	COM2007-00653	Lehigh Medical Center	03/12/2007	Approved	
03/06/2007	COM2007-00654	Lehigh Medical Center	03/12/2007	Approved	
03/06/2007	COM2007-00655	Lehigh Medical Center	03/12/2007	Approved	
03/06/2007	COM2007-00263	Shoppes of Lehigh (ONE CELLULAR STOP)	03/06/2007	Approved	
03/06/2007	FIR2007-00478	Lee Blvd Central	03/12/2007	Approved	
03/15/2007	COM2006-02631	Old Fort Bank	03/23/2007	Approved	
03/15/2007	FIR2007-00399	Fire St.#5 Alert One Fire	03/23/2007	Approved	
03/15/2007	COM2007-00892	Popeyes	03/20/2007	Approved	
03/15/2007	FIR2007-00287	Lee West Retail 3419 Lee Blvd	03/23/2007	Approved	
03/15/2007	COM2006-01842	Lehigh Acres Warehouse (REV) Kellers Plaza	03/21/2007	Approved	
03/15/2007	FIR2007-00500	Bella Monte (Hood)	03/20/2007	Approved	
03/15/2007	FIR2007-00499	Bella Monte (Fire Suppression)	03/20/2007	Approved	
03/15/2007	COM2007-00960	Popeyes	03/20/2007	Approved	Dumpster enclosure only.
03/15/2007	COM2006-02994	Deja Cruze Retail Center Bldg "C"	03/23/2007	Approved	Electric & Mechanical Revision Only.
03/20/2007	COM2007-00810	Shoppes of Lehigh	03/21/2007	Approved	
03/20/2007	FIR2007-00085	Lehigh Medical Center	03/20/2007	Approved	
03/29/2007	COM2007-01088	Royal Plaza Renovation	04/02/2007	Approved	
03/29/2007	COM2007-01211	Fire Station No. 4	04/02/2007	Approved	
03/29/2007	FIR2007-00481	Lee Complex	04/02/2007	Approved	

Development Orders Reviewed

Date In	Permit Number	Project Name	From	To	Status	Comments
			03/01/2007	03/31/2007		
03/01/2007	DOS2007-00035	Brauch Building			03/21/2007	Approved
03/15/2007	DOS2004-00282	Whispering Lakes 1			03/23/2007	Approved
03/15/2007	DOS2006-00050	Town Homes At West Greens-North			03/21/2007	Approved
03/15/2007	DOS2007-00054	Dr. Litch More Dental Practice			03/21/2007	Approved
03/15/2007	DOS2007-00065	BEH Investments Parking Lot			03/21/2007	Approved
03/23/2007	DOS2005-00365	lee west commercial			03/23/2007	Approved

04/05/2007

Reviews Completed: 6

Page 1 of 1

DECEASED WRITEOFFS

3-32235-06	11/25/2006	\$	80.00
3-32037-06	10/21/2006	\$	571.00
1-11471-06	12/24/2006	\$	480.00
3-30364	2/28/2006	\$	140.00
3-30819-06	5/7/2006	\$	149.90
1-10873-06	8/12/2006	\$	80.00
1-11208-06	10/26/2006	\$	71.84
1-10446-06	4/14/2006	\$	396.00
2-21435-06	8/5/2006	\$	54.26
2-22078-06	11/7/2006	\$	77.89
2-22145-06	11/18/2006	\$	69.42
2-22430-06	12/29/2006	\$	346.00
2-21463-06	8/8/2006	\$	63.37
1-11324-06	11/20/2006	\$	62.16
2-22385-06	12/24/2006	\$	83.94
1-10037-07	1/14/2007	\$	80.00
1-10968-06	9/1/2006	\$	403.00
		\$	3,208.78

SMALL BALANCE WRITEOFFS

3-31897-06	11/27/2006	\$	20.00
3-32116-06	1/2/2007	\$	20.00
3-32182-06	11/16/2006	\$	23.58
2-21991-06	10/27/2006	\$	8.63
3-31858-06	11/3/2006	\$	15.16
1-10838-06	8/23/2006	\$	7.66
1-11460-06	1/18/2007	\$	25.00
3-32231-06	12/21/2006	\$	12.19
1-10804-06	7/23/2006	\$	25.00
2-21619-06	11/15/2006	\$	10.00
1-11332-06	1/16/2007	\$	25.00
2-21665-06	9/8/2006	\$	10.00
		\$	202.22

COLLECTION CLAIMS TRANSFER

REQUEST TO TRANSFER OFF DEPARTMENT BOOKS FOR ALL CLAIMS MORE THAN 24 MONTHS OLD FROM DATE OF SERVICE:

THESE DATES OF SERVICE ARE FROM JANUARY 2005 THROUGH MARCH 2005
\$ 60,288.62

COLLECTION PROCEDURES WILL CONTINUE ON THESE ACCOUNTS FOR 7 YEARS FROM DATE OF SERVICE.

THE ABOVE BALANCES IN EACH SUBSECTION HAVE BEEN THROUGH THE DEPARTMENT'S AMBULANCE FEE WRITE OFF POLICY.

LEHIGH ACRES FC & RD
March 2007 Period 6 Operations Report

	This Year		Last Year	
	Month	Year To Date	Month	Year To Date
Total Expenses:	0.00	0.00	0.00	0.00
Total Transports:	329	1948	347	1842
Total Resp Fees:	0	0	0	0
Cash Transports:	87,408.01	462,170.89	77,129.91	453,835.78
Cash Resp Fees:	0.00	0.00	0.00	0.00
Total Cash:	87,408.01	462,170.89	77,129.91	453,835.78
Total Disc. & W/O:	45,056.96	335,573.10	33,362.17	225,319.39
Total Charges:	132,491.00	779,827.00	146,962.00	768,533.00
A/R Balance:	26.03	277,803.56	36,469.92	356,031.05
Cost Per Call:	0.00	0.00	0.00	0.00
Cash Per Transport:	265.67	237.25	222.27	246.38
Collection Rate:	65.97	59.26	52.48	59.05

Discount and Writeoff Summary

	This Year		Last Year	
	Month	Year To Date	Month	Year To Date
Discounts:	0.00	0.00	0.00	0.00
Unclassified:	0.00	0.00	0.00	0.00
Medicare Contract:	3,876.32	23,108.10	2,496.23	26,625.16
Medicaid Contract:	10,735.08	59,132.14	11,526.48	56,619.06
Insurance Contract:	0.00	0.00	0.00	0.00
Charity:	0.00	0.00	0.00	0.00
Bad Debt:	29,461.29	245,452.66	16,209.08	142,854.45
Other:	984.27	7,880.20	3,130.38	-779.28
Total Writeoffs:	45,056.96	335,573.10	33,362.17	225,319.39
Adj. Collection Rate: (After Medicare and Medicaid Contractual Adjustments)	74.15	66.25	58.01	66.22

Sue Platas

From: Anita Hatten
Sent: Wednesday, April 11, 2007 9:17 AM
To: Sue Platas
Subject: New Account

Sue,

Please ask the commission to approve the new account number of 336-0102 for the Paul J Dube Paramedic Fund. This account number will allow us to track the money donated to this fund and keep that money separate from our general fund.

Thanks,
Anita

4/16/2007

To: Chairman of L.A. Fire Control and Rescue District
Mr. Ralph Hemingway, Jr.

Chief of Department
Donald R. Adams, Sr.

From: Commissioner-Seat # 4
D. Bruce Boyd Jr.

Notice of Future Resignation

I would like to inform you I am planning on resigning on June 21st, 2007.

I have been on the Board for 11 years and 8 months as of this date. I am planning on moving out of state and I feel that I need to resign so the Board may have time to find a person to fill my term which runs till November 14th, 2008. This way the new commissioner could be involved in Budget and Contract Negotiations.

I have enjoyed my time serving the **Citizens of Lehigh Acres** in helping to provide the **Top Level Service** that they deserve and expect. I have also been involved in providing the Department, when financially feasible, the latest and best equipment available for EMS and Fire Service. In 2001 the Board drafted the first 5 year plan. We did this with the help of 12 personnel that served on the planning team. Many things have changed since then, but the basics of that plan still exist today. I was hoping to be on the Board when Stations 4 and 5 are dedicated. Even If I have moved before then I will come back to see them dedicated.

My first term was for 5 years, The next two I ran unopposed for 4 year terms. I have had a good run but now it is time for a new person and new ideas. Although I will no longer be a Commissioner I will support the Department and all the personnel in any way that I can.

God Bless,
Bruce Boyd

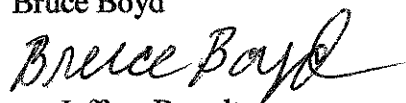

- cc: Jeffrey Berndt
- Joel Guzman
- Julie A. Barrett
- Susan Platas
- Richard Pringle